

Land Managerⁱ Application Control

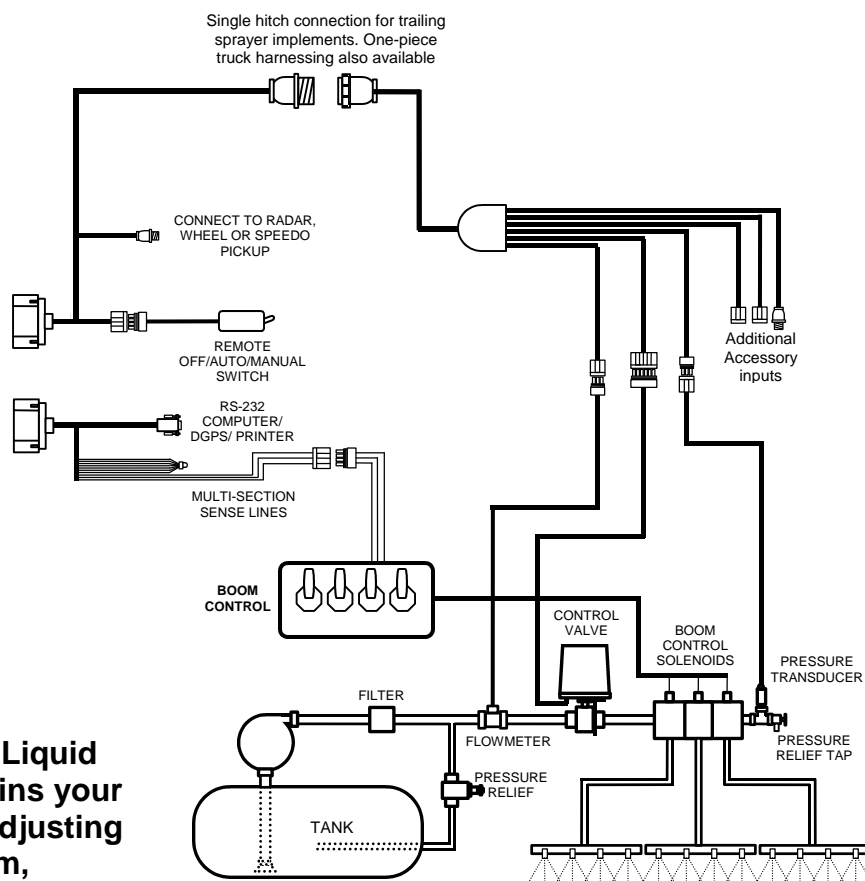

Sprayer Control System

Breakthrough Technology



The DICKEY-john Land Manager Liquid Control System precisely maintains your desired l/ha application rate by adjusting the flow of chemical to your boom, automatically accommodating changes in ground speed, boom state and other system dynamics in real-time. No other control system comes close to the precision of Land Manager.

The system has an extensive range of liquid control features and offers a significant improvement in the ease of programming and operation of liquid application while providing industry leading precision and accuracy. The operator can instantly read the application rate, flow rate, pressure, speed, area accumulated, boom section status, accessory information, product and area accumulators, and tank levels on the console and can swap between imperial or metric units. Application rates can be changed on-the-go for spot application. Proven DGPS variable rate control compatibility is built in to the unit ready to meet your precision farming requirements.

Land Manager can store 10 different application setups and 10 individual formal reports on your applications including start and finish times, litres applied and area covered.

Land Manager is compatible with most existing sprayer hardware making upgrading to Land Manager simple, and it can directly drive some chemical pumping systems, eliminating the need for a separate flow control valve. The system can operate in flow, pressure or both modes to meet your requirements or preferences.

DICKEY-john products are built for years of easy trouble-free operation. As with all DICKEY-john products, Land Manager is backed by a fully accredited Australian Service Centre.

CAMBUT
5 Manilla Street, P.O.Box 7101,
East Brisbane Queensland 4169.
Phone: 07 3391 8766 Fax: 07 3891 1761

We Think Ahead. We Design To Last.

DICKEY-john Land Manager Real-Time Control System

Land ManagerTM is a proven multi-purpose one or two channel control and monitoring system that gives you precise, **real time** control over the application of material from your liquid, anhydrous, granular spreader or seed applicators- all in one unit!

Manufactured by DICKEY-john Corporation, the leader in innovative design and production of electronics for agriculture, *Land ManagerTM* offers a number of features that improve user comfort and efficiency. It has a large, easy to read backlit LCD display for viewing in direct sunlight or at night, a very simple user friendly menu driven interface for setup and operation in either metric or imperial units, and a number of automated functions to simplify daily tasks. The display and control electronics are all housed in a rugged, weather-sealed alloy console. All system components are designed specifically for the demanding agricultural environment and are proven reliable.

The control system intelligently maintains your desired application rate in real time as your ground speed, system dynamics, and (in conjunction with a suitable DGPS unit) position in the paddock changes. This results in fast and accurate control system response – a must for true 'precision farming' applications. *Land ManagerTM* is packed with control features that adapt to your particular requirements. Just some of these features include:

- Precise, real time control of one or two separate operations at the same time.
- Master switch module located anywhere in the cab providing On/Off/Manual operation.
- Change your target application rate on the go with the push of a button.
- Automatic/manual tuning optimises the response of the controller to suit your particular applicator.
- Simple, easy to use calibration functions eliminate manual calibration calculations.
- Valve locking keeps system charged for instant response when pulling in/out.
- Combination standard and fence row boom configurations.
- Loading/unloading and agitation modes.
- Minimum/maximum application rate. Minimum speed override, Minimum speed cutout.
- Manual override of ground speed and valve position.
- Built-in Service and Troubleshooting Menu.
- Selective Password Protection allowing Supervisors or Managers to limit Operator access to control setup.

The *Land ManagerTM* main display is clearly and sensibly laid out so that you can monitor all of the following parameters at a glance:

- Your actual application rate (l/ha, kg/ha).
- Flow rate or boom pressure (l/min, kg/hr, bar).
- Active applicator boom sections including split-belt spreaders or multi-section air booms (up to 10 sections).
- Speed and area.
- Control and monitor alarms.

And with simply the push of a button, a host of other information is available to the Operator:

- Accessory inputs such as spinner speed and hydraulic fluid temperature.
- Product accumulation: area and total product; product level (with alarm).
- System area, date, time.
- An alarm history logs the date and time when application events occur (travelling too fast, too slow, spinner speed out of range, hydraulic fluid too hot, etc).

Up to 10 controller setups can be stored for easy retrieval at any time making switching between product type setups and different rigs or nozzle configurations very simple. A detailed formal reporting facility is also built in to allow viewing and recording of up to 10 applications on the screen, computer or printer.

You can monitor and display information for up to 10 boom sections and a boom control module is available separately. The system is 2 or 3-way boom control solenoid/valve compatible. Optional Spinner/Auger and multi-section hydraulic controls are available for your spreader.

To ensure compatibility with precision farming technologies and software developments, *Land ManagerTM* is fully field upgradable and has **proven** full-featured DGPS compatibility built in. This means that you do not have to purchase new hardware when features or enhancements are added to the system. It comes ready to connect directly to your DGPS system that supports the DICKEY-john controller protocol. In addition, it is completely compatible with previous DICKEY-john system parts including control valves, flowmeters, pressure transducers, anhydrous ammonia control systems, shaft speed sensors and all radar ground speed sensors. It is also compatible with most existing hydraulic and electric drive systems.

Land ManagerTM is one of the **BENCHMARKTM** series of products from DICKEY-john - a whole new generation of electronic control and monitoring products designed to complement the technological advances of precision farming. For further information on the DICKEY-john range of products, please contact your local representative. Or, you can call Cambut Holdings directly on (07) 3391 8766, e-mail us at info@cambut.com.au, or visit our web site at <http://www.cambut.com.au>.